

Swing

Pressure Treated Lumber



Georgia-Pacific



Swing

Every porch needs a swing! Unwind after a long day and watch the stars from this comfortable and well constructed swing. Built using Georgia-Pacific Treated Lumber the plans are easy to follow for the experienced carpenter. Enjoy fun filled relaxing evenings.

Georgia-Pacific Corporation makes no warranties expressed or implied, regarding this plan and specifically disclaims the warranties of merchantability and fitness for a particular purpose. Check with an architect or a building expert to make sure that this plan is appropriate to your situation and meets local building codes. Read carefully the consumer information sheet on pressure treated wood before starting construction.

Materials Checklist

- 1–2" x 8" x 8' cut to:
 - 2–26" armrests (horizontal), notch 1/2" to hold front and side arm supports. Cut a hole or shallow depression to fit your favorite cup. Curve edges.
- 3–2" x 4" x 8' cut to:
 - 2–17 1/2" side seat supports. Cut tops to conform to a comfortable seat curve as shown. Cut backs at 9 1/2° angle.
 - 1–52" bottom back support (horizontal). Lag bolt to side seat supports.
 - 1–52" center back support (horizontal). Sand or sawcut ends to fit against armrests and screw tight to arm rests and back arm supports.
 - 1–52" front seat skirt (horizontal). Cut decorative curve. Lag bolt side seat supports 2" from ends.
 - 2–13" front arm supports (vertical). Cut decorative curve. Attach to front seat skirts with carriage bolts and nuts. Glue top edges and fit into armrest notches. Screw eyebolts for chain through armrests into arm supports.
 - 2–14" back arm supports (vertical). Cut tops at 9 1/2° angle, then glue and fit into armrest notches. Screw eye bolts through armrests into arm supports as above. Trim bottom edges and lag bolt bottoms to side seat supports.
- 6–1" x 4" x 8' cut to:
 - 1–48" top back support (horizontal)
 - 4–48" seat slats (horizontal). Screw to side seat supports.
 - 4–30" back slats (vertical)
 - 4–34" back slats (vertical)
 - 2–35" back slats (vertical) Cut tops of back slats as shown and screw to all horizontal back supports.
- 2–10' lengths of galvanized steel chain or longer to fit your porch ceiling so seat is 16" from floor.
- 6 3/8" x 4" eye bolts.
- 2 5/16" S-hooks or clips to hold chain.
- 6 5/16" x 4" lag bolts with washers.
- 2 3/8" x 3 1/2" carriage bolts with nuts and washers.
- 1 box of deck screws, stainless steel or galvanized. For a finished look, recess screw heads and fill with wood plugs or putty.
- Water-repellent wood glue. Finish with water repellent or stain or three (3) coats of exterior paint after wood is thoroughly dry (may take several months of exposure for pressure treated wood to dry). This swing is in the adirondack style. It is traditionally painted in a bold solid color.
- Pressure treated wood is recommended for exterior use. If you are confident of your skill, you may wish to use an expensive, naturally rot-resistant wood. For heavy use, eyebolts need glue and add a nut by drilling to the bolt end from the side.

Builder is responsible for ensuring that whatever the swing is secured to can support the weight of the swing and its occupants.

Did you know?

- **Pressure treated wood** may be painted or stained to match any outdoor color scheme. High-quality latex-based paints and oil or latex stains are recommended. Make sure the wood is dry and free from surface deposits before applying any coating.
- **Water repellent coatings** can be applied to enhance the long-term weathering performance.
- **Only wood** that is visibly clean and free of surface residue should be used for patios, decks and walkways.
- **To help maximize surface protection** and to keep your wood looking better longer, GP recommends applying a surface water repellent every two years.

Questions and Answers

Q What kinds of projects are ideal for pressure treated wood?

A Choose GP pressure treated wood for decks, porches, gazebos, planters, arbors and other outdoor structures. You'll enjoy the beauty of wood plus long-lasting performance.

Q How do I dispose of unused wood?

A Scraps and sawdust should be disposed with ordinary trash. Do not burn treated wood, as toxic materials may be produced as part of the smoke or ashes.

Q What is ACQ?

A Alkaline Copper Quaternary (ACQ) is a chemical solution used as a preservative treatment for wood to help provide long-term protection from rot, decay and termites. The main active ingredient in ACQ is copper, which has long been established as the most cost-effective preservative component used in preserving timber. Quaternary acts as the co-biocide in the ACQ preservative, providing additional protection from decay, fungi and termite attack that copper alone would not control. Copper and quaternary solutions similar to ACQ are used for the control of fungi and bacteria in swimming pools and spas.

Q How long has ACQ been in use?

A For more than a decade, ACQ has been used in neighborhood playgrounds, backyards and other outdoor projects.

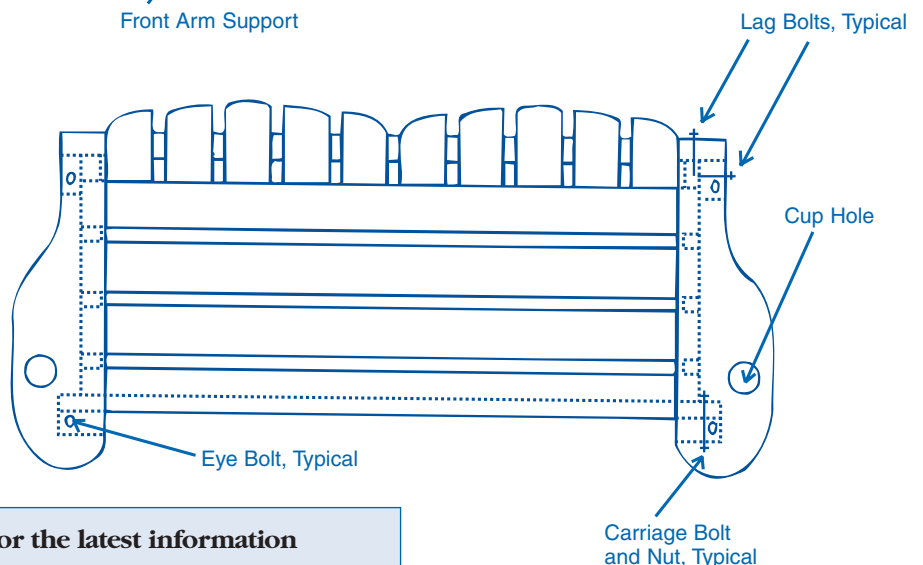
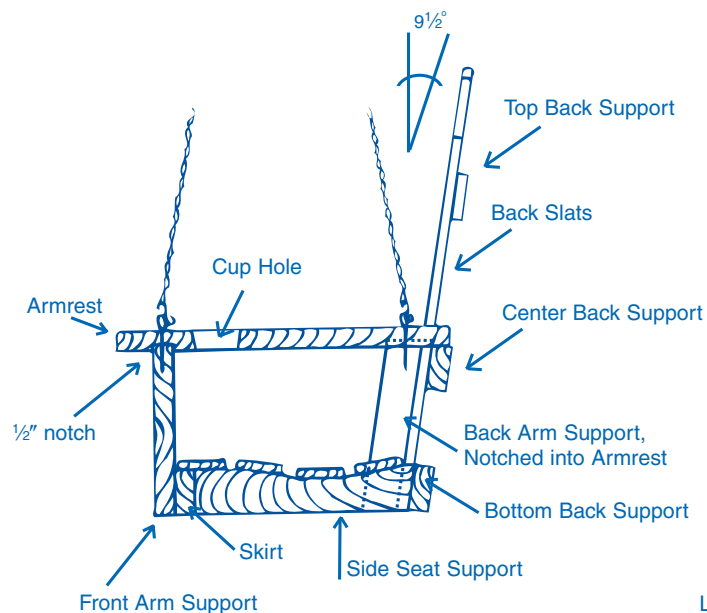
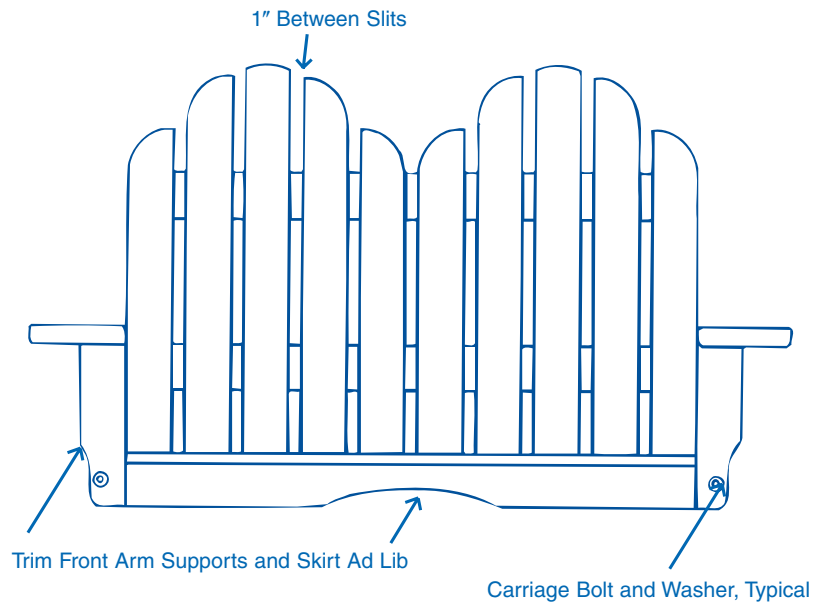

For the latest information about pressure treated wood, visit www.gp.com, or call 1-800-282-0600.

Safety Dispatch

Build Safely with Pressure Treated Wood

Whether you're building a new planter or replacing your deck, Georgia-Pacific pressure treated wood is the high performance decking choice. The projects you build with Georgia-Pacific pressure treated wood products should last a long time. So, it makes good sense to build in a craftsman-like manner. Here are some helpful tips to make your job easier and look better.

1. Recommended Fasteners

Use only hot-dipped galvanized or stainless steel fasteners, connectors and hardware to help safeguard the structural integrity of projects built with ACQ treated wood.

As a minimum requirement for use with ACQ treated wood, hot-dipped galvanized

coated fasteners should conform to ASTM Standard A153 and hot-dipped galvanized coated connectors should conform to ASTM Standard A653 (Class G-185). In demanding applications, such as treated wood foundations and playground equipment, use of stainless steel fasteners and connectors should be utilized and may be required by building codes.

Electroplated galvanized fasteners are not recognized as being corrosion resistant for exterior applications. Aluminum should not be used in direct contact with ACQ treated wood.

2. Nail bark side up

Always nail boards bark side up (annual rings arc upward) to reduce cupping. Nail thin boards to thicker boards to help maintain structural integrity.

3. Drill pilot holes

Especially when nailing near the edge or end of a board, it's a good idea to drill pilot holes for your fasteners.

4. Butt boards tightly

Butt decking boards together firmly. As drying occurs, some shrinkage can be expected.

5. Apply a weather resistant finish.

Any exposed wood, pressure treated or not, should be protected from the weather. Application of a finish coat of clear or semi-transparent water-repellent stain will help to minimize warping, checking or splitting. The finish coat should be applied immediately to untreated wood and to pressure treated wood as soon as the surface is dry.

Safety First

Pressure treated wood is easy to work with. The following simple safety procedures are recommended.

- Do not burn treated wood. Toxic materials may be produced as part of the smoke or ashes.
- Clean up scraps and sawdust after construction and dispose by ordinary trash collection.
- Gloves should be worn to protect against splinters and abrasions.
- A dust mask should be worn when sawing, machining or sanding any wood to reduce the inhalation of wood dust. Whenever possible these operations should be performed outdoors to avoid indoor accumulations of airborne sawdust from treated wood.

- Appropriate eye protection should be worn to reduce the potential for eye injury from wood dust or particles and flying debris during machining and construction.
- After working with pressure treated wood, thoroughly wash your hands and exposed areas thoroughly with mild soap and water before eating, drinking or using tobacco products.
- Because preservatives or sawdust may accumulate on clothes, they should be laundered before reuse. Wash work clothes separately from other clothing or household items with which you may have contact.
- Treated wood should not be used where it may come into direct or indirect contact with drinking water, except for uses involving incidental contact such as fresh water docks and bridges.

Use Site Precautions

ACQ treated wood may be used both inside residences (should be clean and free of surface residues) and outdoors. However, it should not be used in or on sites where it could come into contact with food, animal feed or drinking water.

Examples of such sites are as follows:

1. Structures for storage or handling animal feed, (grain, silage, etc.) such as silos, feed troughs or bunks.
2. Use as kitchen countertops or cutting boards.
3. Use in construction of those portions of beehives which may come into contact with the honey.
4. Structures that would be in direct or indirect contact with drinking water, except for uses involving incidental contact such as residential fresh water docks and bridges. **ACQ treated lumber should not be used in salt-water immersion applications.**
5. Do not use ACQ treated lumber residues, such as sawdust and shavings, as mulch.



Georgia-Pacific Corporation
Building Products
55 Park Place, N.E.
Atlanta, GA 30303
1-800 BUILD GP
www.gp.com/build

©2005 Georgia-Pacific Corporation. All rights reserved.
Printed in the U.S.A. 8/05.